



Department of
Engineering Science
Electrical Engineering

Senior Design Project Progress Report
EE 493 Senior Design Project

**Autonomous Recharging of Unmanned Aerial Vehicle
(ARAV)**

By:

Alexander McGinnis
Joseph Haun
Anthony Aboumrad

Spring 2020

Faculty Advisor: Dr. Nansong Wu, Sonoma State University
Industry Advisor: Dr. Pelin Salem, Senior Engineer, Cisco Systems
Client: K.R. Zentner, USC Robotics Research Laboratory

Project Website: <https://mcginnisa.github.io/ssuav/>

Acknowledgments

We would like to thank and acknowledge our faculty advisor, Dr. Wu, our industry advisor, Dr. Salem, our campus woodshop technician, Aimee Graham, our CAD modeling professor, Tom Greer, as well as the rest of the Sonoma State University Electrical Engineering Department faculty for their extremely valuable support and guidance during our college careers.

Abstract

Unmanned Aerial Vehicles (UAV) are gaining popularity due to their agility and ease of manufacture. However, due to battery life limitations, longer autonomous flight patterns are not feasible for most of these vehicles. There is an imminent need among researchers and industry engineers alike to develop UAV systems capable of supporting autonomous recharging routines for a variety of applications. Our proposed solution to this problem is the creation of an autonomous system involving a lightweight UAV paired with an intelligent charging platform. The charging platform will be equipped with an on-board camera and single board computer (SBC) capable of accomplishing image recognition of the UAV. Combined with an onboard wireless charging pad, these key elements of the charging platform will support the autonomous landing and recharging of the UAV. The charging platform will further be designed as a portable subsystem capable of being deployed quickly and conveniently in an indoor laboratory setting, thus allowing for further developments in autonomous vehicle applications.

Table of Contents

Acknowledgments	1
Abstract	2
Table of Contents	3
List of Figures	5
List of Tables	5
Problem Statement	6
Introduction	6
Literature Review & Previous Works	7
Methodology	9
Fig. 1 - Operating Model of System	11
Challenges	12
Project Requirements	14
Marketing Requirements (MR)	14
Engineering Requirements (ER)	14
Implementation	15
System Architecture	15
Fig. 2 - High Level Block Diagram	15
Fig. 3 - Block Diagram of Charging Platform	16
Fig. 4 - CAD Render of Proposed Charging Platform	17
Fig. 5 - Landing Routine Software Flowchart	17
Budget/Parts List	17
Table 1 - Single Board Computer Design Matrix	18
Table 2 - Camera Design Matrix	18
Table 3 - Qi Charger Design Matrix	19
Table 4 - Summary of parts required and project budget	19
Project Schedule	21
Table 5 - Gantt chart for project schedule	22
List of Tests	23

Autonomous Recharging of Unmanned Aerial Vehicle

Summary of Tests	23
Table 6 - Summary of tests	24
Description of Tests	25
Fig. 6 - Software Landing Accuracy vs. Detection Method	26
Fig. 7 - UAV Command Latency vs. Distance	27
Fig. 8 - Landing Sequence Duration vs. Detection Method	32
Fig. 9 - Detection Range vs. Method	33
Preliminary Results	34
Customer Survey	36
Regulation Compliance of Our Project	37
Ethics of the Engineering Profession and Our Project	38
References	39

List of Figures

Fig. 1 - Operating Model of System	11
Fig. 2 - High Level Block Diagram	15
Fig. 3 - Block Diagram of Charging Platform	16
Fig. 4 - CAD Render of Proposed Charging Platform	17
Fig. 5 - Landing Routine Software Flowchart	17
Fig. 6 - Software Landing Accuracy vs. Detection Method	26
Fig. 7 - UAV Command Latency vs. Distance	27
Fig. 8 - Landing Sequence Duration vs. Detection Method	32
Fig. 9 - Detection Range vs. Method	33

List of Tables

Table 1 - Single Board Computer Design Matrix	18
Table 2 - Camera Design Matrix	18
Table 3 - Qi Charger Design Matrix	19
Table 4 - Summary of parts required and project budget	19
Table 5 - Gantt chart for project schedule	22
Table 6 - Summary of tests	24

1. Problem Statement

Completely autonomous unmanned aerial vehicle (UAV) systems have immense potential to solve modern problems in novel ways. Industry professionals and public institutions alike are actively researching the potential of these vehicle systems to perform a variety of automated tasks, such as: field surveillance, search-and-rescue operations, and parcel delivery [1]. The types of UAV systems being developed by engineers and scientists exhibit significant variability with regard to overall system cost and functionality. Smaller and lower-cost UAV systems often suffer from limited support of vehicle-mounted sensors and/or real-time processing of navigational data from the UAV itself. This presents a significant challenge to UAV system developers working with more accessible vehicle platforms, as some of the most difficult and dangerous parts of any aircraft's utilization are its take-off and landing routines. Additionally, battery life limitations among more budget-friendly aerial vehicle options typically make longer autonomous flight routines impractical or unfeasible.

A solution is therefore needed to accomplish the autonomous landing and recharging for such an economical UAV system. A system which supports these autonomous behaviors would therefore allow developers of UAV applications to overcome some of the limitations imposed by the use of affordable, lightweight aerial vehicles. The solution proposed by this project seeks to tackle a key challenge of autonomous and unmanned aircraft missions in an accessible and generalizable way.

2. Introduction

Unmanned aerial vehicles are capable of nimble and autonomous flight, and there are numerous UAV applications – including the ones previously described – which would benefit greatly from the availability of automated battery recharging systems. These systems would support remotely recharging UAVs actively engaged in programmed flight routines and without the aid of a human operator. The development of UAV applications is being performed by individuals and institutions with varying levels of material resources, and smaller organizations and labs must often work with low-cost, feature-constrained vehicular systems. Therefore, the limitations on the features supported by a budget-friendly UAV system effectively become limitations on the range of UAV applications that may be successfully developed by smaller institutions.

Our goal was to develop a system that involves an unmanned aerial vehicle functioning in tandem with an intelligent and portable charging platform. The UAV performs an automated flight routine and alerts the charging platform when a particular low-battery threshold is reached. When alerted, the system initiates an automated landing sequence. The landing sequence aligns the UAV through the use of the charging platform's onboard sensors, and sends commands for

mid-flight position adjustments over a radio module. This synchronized landing routine allows the UAV to touch down on the charging platform, which integrates an inductive coil wireless charging pad capable of recharging the UAV's on-board battery without the need for a physical port connection. To allow for software configurations and diagnostic testing, the charging platform's onboard control computer is made accessible to developers over a local network.

The automated landing sequence was able to successfully interpolate precise positioning information of the UAV with respect to the wireless charging pad. Thus, the UAV may land directly on the wireless charging pad as needed while executing a variety of potential flight missions. The system functions on flat ground, in indoor scenarios that will demonstrate its viability for real world applications. We expect this landing-and-recharging routine to be a significant contribution to further developments in the world of autonomous UAV flights, especially as it pertains to budget-friendly devices.

3. Literature Review & Previous Works

Commercial use of battery-powered unmanned aerial vehicles (UAV) for various observation tasks has become popular with the increasing availability and affordability of instruments such as heat sensors, LIDAR, and cameras [1]. While the viability of UAV use has vastly increased, these vehicles generally have limited flight time [2]. Longer UAV flight routines could be made possible by the development of systems whereby the UAV operates in tandem with an unmanned ground vehicle (UGV) designed to function as both a landing pad and battery recharging station for the UAV. Such UAV-UGV systems are not commercially available, but they have been revealed to be in development by companies such as UPS [3]. Due to increased demand on shipping companies as online shopping services have risen in popularity [4], a system that can be used to autonomously recharge a UAV (or, in certain cases, an entire fleet of UAVs) is desirable for research institutions, commercial entities, and government agencies.

In an ambitious project from Wenzel et al., a UAV-UGV pair system was developed for testing techniques to land a quadcopter on a moving platform. This project is highly relevant to the ARAV project due to its heavy reliance on affordable machine vision hardware to determine the position and orientation of the moving platform, as well as the use of micro-quadcopters [5]. This system leverages a Wii Remote infrared constellation sensor to track the position of the landing pad. This is an elegant solution because the Wii Remote removes the machine vision processing burden from the main flight microcontroller, leaving precious resources for the proportional-integral-derivative control loop. The microcontroller aboard the UAV is free to run a control loop at an update frequency of 50 Hz [5]. Critically, the tracking system is also very light, at under 10 grams, which allows for a much longer flight time than a bulky camera. The modularity of the system also allowed different aerial vehicles to be tested with the UGV location system. An Atmel ATmega 644P microcontroller was used as the main flight controller,

and a ZigBee local area network was established between a ground station and the UAV for control, much like our system. The entire infrared tracking system consumes 1.8 W of power, and the four motors aboard consume a maximum of 222 W [5]. The camera from the Wii Remote was removed and stripped of its Bluetooth module, so that the camera could be run at three times the refresh rate, as well as allow for a reduction in power consumption and size. The Wii Remote camera was fitted on a servo mounted to the UAV, so that the constellation could be tracked in its narrow 45 degree vision cone without needing to pitch the aircraft. The infrared constellation on the UGV consisted of a three-dimensional four-beacon configuration, which provided orthogonal axes between the beacons for tracking from any azimuth or elevation. There was a design tradeoff in the distance between the beacons. If the beacons were too far apart, the constellation wouldn't fit in the vision cone of the Wii Remote camera, however if the beacon constellation was too small the camera wouldn't be able to resolve the distinct points at a distance. This system is highly similar to the proposed ARAV system, and several features of this system can inform ARAV design choices. The system still maintains the camera aboard the UAV, burdening the UAV with image recognition power consumption and an extra camera payload. The ARAV system will relieve the UAV of this responsibility [5].

Another dual system developed by Jae-Keun Lee et al. supported the continuous and autonomous tracking of a UGV's position by a UAV equipped with a downward-facing camera, much like the ARAV project. [6] Images captured by this camera were wirelessly transmitted to a remote PC which in turn recognized the position and orientation of a unique monochromatic symbol on the upper face of the UGV's landing platform. The interpolated position of the UGV within the UAV's image frame was then issued to issue controls to the UAV from the remote PC, thus ensuring that the UAV maintained a stable hovering position over the UGV at all times. The use of a simple visual pattern to determine all necessary UAV controls in this case is comparable to our unique control scheme, however this system does not implement autonomous UAV flight commands besides those necessary to maintain a fixed position relative to the UGV, nor does it take into consideration any battery recharging needs that would arise for longer flights. In contrast to the proposed ARAV system, mounting a camera on the UAV rather than the UGV precludes the use of smaller and more affordable aerial vehicles for broader research into related applications. This project informed our investigation into April Tag detection techniques.

As dual systems are being implemented more frequently, common problems are arising from the limited computational power of the aerial vehicle, which is a shortcoming the ARAV system aims to address. As noted by Yingxin Wei, UAV sends telemetry via wireless signals which are susceptible to distortion and transmission delay [7]. This project is relevant to the system being developed as it describes optimizations for UAV-UGV pairs with the primary processing core available on the drone. This primary processing core handles image processing as well as flight for the drone which causes a large battery draw for the drone. The processing is

done by a Raspberry Pi which is a fairly low-power Linux machine which is capable of communicating over IEEE 802.11 with the UGV. The transmission consists of PWM signals which enable the movement of the UGV toward the UAV. The system developed by Yingxin Wei was used as a testbed for low-power algorithms that would produce similar performance in the detection and direction of the UGV. The tests performed were intended to simulate a real-world scenario in which the UGV would follow the UAV through various obstacles - in this case, a series of light beacons revealing a path for the UAV to locate and use to direct the UGV. This UAV-UGV pair was directed by an algorithm that optimized the UGV's route towards the UAV-identified light beacon. While this algorithm was effective, Yingxin Wei notes that it is prohibitively expensive due to the computational complexity [7]. Despite the proposed approximation, which showed promise in the aforementioned simulations done, the applicability of the research was deemed to be largely confined to systems involving larger and more expensive aerial vehicles than those most appropriate for the scope of this project.

4. Methodology

Given the existing limitations on autonomous landing and battery recharging behaviors by affordable, lightweight UAVs, our team proposed a paired system consisting of a small UAV and a portable charging platform. The proposed system incorporates some of the techniques used in prior research, as well as some novel control mechanisms of our own design. These major design decisions were informed by some of the most relevant research available on the topic of UAV-UGV control systems, as described above. Additionally, the decision to design the landing surface as a portable platform, as opposed to a complete UGV subsystem, was based on the desire for our system to be compatible with a variety of mountable surfaces and locations. This would broaden the range of applications for which our autonomous system could be deployed.

The UAV was expected to have adequate agility for making targeted landings, and thus the accurate positioning of the UAV over a recharging station entailed the transmission of flight control commands from a single board computer (SBC) to the UAV over a compatible radio module. The control commands themselves are calculated by an algorithm that interprets information about the UAV's altitude and position. By offloading as much of the necessary computational features as possible to the charging platform, the power supplied to the UAV could be prioritized for accomplishing extended flights or other task completion behaviors.

The altitude of the UAV is queried from an onboard range sensor, and positional data is extrapolated from an image of the UAV as seen from an upward-facing camera module mounted on the charging platform. The location of the UAV, relative to its target landing point upon the wireless charging pad, was determined by an image recognition scheme involving the use of infrared LED beacons mounted on the underside of the UAV. The transformation of the UAV pixel-coordinates within the frame of the OpenMV camera to world coordinates (x_n, y_n, z_n) was

accomplished by using the following equations, where S is the size of the individual sensor, P is the pixel coordinate, h is the height of the UAV, and f is the focal length of the camera.

$$\begin{aligned}x &= (h/f)S_x(P_x - P_{x\text{-offset}}) \\y &= (h/f)S_y(P_y - P_{y\text{-offset}})\end{aligned}$$

To determine if the UAV is within an acceptable area for downward movement, a logarithmic function is leveraged to provide a maximum offset from the central charging point. This equation, shown below, allows for a greater acceptance at higher altitudes with a narrower acceptance the closer the UAV is to the charging point. The larger acceptance areas account for hardware faults of the UAV and camera by allowing the UAV to move closer to the camera without requiring the desired end accuracy. This means that the UAV will make more movements overall, but prevents a system failure or stalling by constantly being able to make UAV movements.

$$h_{UAV} = \log_R(A_h) + H_{\text{offset}}$$

At a functional level, this provides a virtual horn structure in 3D space that the UAV must be within to be considered for downward movement. The radix, R , of the logarithm is used to determine the severity of the function slope and the H_{offset} value is used to ensure that the minimum area above the landing target is not smaller than the physical UAV dimensions which may prevent further downward movements. The above equation is solved for the A_h parameter, which provides the area measurement, and the variable input to this function is the current height of the UAV, h_{UAV} .

The relative bearing of the UAV with respect to the world frame was determined by making naive movements of the UAV and determining the angle between the expected end point and the actual end point, as observed by the camera. If this orientation difference, Θ_{diff} , was below a threshold as set by the operator of the system, any changes were discarded to prevent compounding errors in future movements. In the case where the relative bearing of the UAV deviated significantly from the world frame, a transformation of subsequent x-y flight commands was performed as needed. Defining E as the expected UAV position vector after issuing a set of x-y flight commands, and K as the actual position vector after movement, we can make use of the calculated Θ_{diff} to generate the transformed x-y flight commands (x_T, y_T) for subsequent movements.

$$\begin{aligned}\Theta_{\text{diff}} &= \tan^{-1}([E_x K_y - E_y K_x] / [E_x E_y - K_x K_y]), \\x_T &= x \cos(\Theta_{\text{diff}}) + y \sin(\Theta_{\text{diff}}) \\y_T &= -x \sin(\Theta_{\text{diff}}) + y \cos(\Theta_{\text{diff}})\end{aligned}$$

As shown in Fig. 1 below, the operational model of the entire system was such that UAV coordinates (x_n, y_n, z_n) are interpreted by the SBC and then compared against target position L in the landing space. Positional errors Δx , Δy , and Δz are determined by the SBC from reading the camera output.

$$\begin{aligned}\Delta x &= x_n - x_L \\ \Delta y &= y_n - y_L \\ \Delta z &= z_n - z_L\end{aligned}$$

These positional errors are then used to generate flight commands. As $(\Delta x, \Delta y) \rightarrow 0$, the SBC instructs the UAV to descend ($z_n \rightarrow z_L$). This model correctly lands the UAV to within the desired precision, regardless of differences in height between the target landing point and the position of the camera, so long as the target landing point is able to be projected onto a plane that overlaps with the view space, V_T .

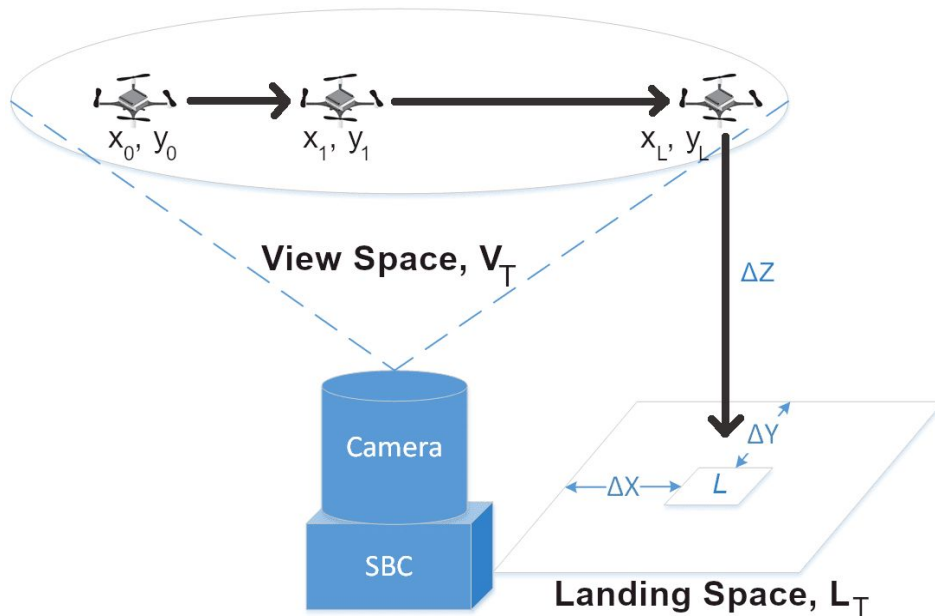

Fig. 1 - Operating Model of System

Due to the great difficulty in performing an extremely precise autonomous landing, the means of recharging the UAV upon touchdown is through an inductive charging interface using a widely-available wireless charging standard. This eliminates the need to maneuver the UAV toward an even smaller range of acceptable landing positions, as would be the case if direct contact of physical power ports were necessary to recharge the UAV battery. While the UAV

battery power is restored by the inductive recharging provided by the wireless charging pad, the complete charging platform system (including the camera and radio modules, single board computer, and wireless charger itself) is powered by a large, mounted battery pack.

5. Challenges

While some of the project risks forecasted early in development were resolved without much complication, other unforeseen obstacles posed serious challenges that either delayed the completion of certain aspects of our implementation or warranted the adoption of different technical solutions entirely. One notable example of the former involved our initial concern over the aerial vehicle's "ground effect" - the problematic turbulence which results from an aircraft getting too close to the ground. While we expected to encounter an impairment to autonomous navigation and landing accuracy due to this turbulence, the native PID control firmware of our chosen UAV model (Bitcraze Crazyflie 2.1 quadcopter) proved to be competent at maintaining relatively-stable landings.

In consideration of a realistic deployment of our system, a potential challenge in its long-term operation is the build-up of dust on the upward facing camera lens that could cause reflections and obstructions of the incoming light. As this factor might require complicated automated systems to regulate, the instructions for care and operation of the system may include a preliminary inspection of the lens and cleaning if necessary.

One of the greatest challenges faced during the course of this project was refining the landing software in order to satisfy our target landing accuracy. By making use of the operational model described above, in conjunction with deriving a reliable means of determining UAV position from visual feedback, we were able to develop a software control algorithm that was capable of reliably landing the UAV within 5 cm of a target point. Per the mathematical model, the UAV and camera have separate mathematical frames of reference. The camera treats its own frame of reference as the world coordinate frame and attempts to match the UAV frame of reference to the world coordinate frame through calculation after a movement command is executed by the UAV. Before the movement occurs, the single-board computer logs the starting position of the UAV for later purposes. Once a movement is completed, the single-board computer calculates the expected end position of the UAV within its own coordinate system and then compares that with the reported end position of the UAV by the camera. The comparison occurs by calculating the difference between the actual and expected coordinates. If the difference between expected and actual was outside a specified threshold, the movement vectors were calculated and then used to determine the offset angle. This offset angle was then used in any future movements of the UAV to transform world coordinates to UAV coordinates. Since the coordinates are transformed from the world frame to the UAV frame, the movement of the UAV will correspond to the end positions as determined by the single-board computer. As these values should coincide, the landing algorithm will throw away future transforms unless other

errors affect a future movement. This iterative process prevents compounding errors by requiring computation of a new transform whether or not it will be used

The generation of effective machine vision data, however, required numerous iterations with various image detection schemes supported by our digital camera, the OpenMV Cam H7. An initial testing of machine vision capabilities showed promise with both April Tag detection and RGB LED detection (the later of which was shown by Wu et. al [8] to be a viable detection scheme for the Crazyflie quadcopter). However, April Tag detection had an insufficient range of operation for our purposes, and RGB detection made use of a resource-intensive detection method that noticeably slowed the frame rate of the OpenMV camera. Frame differencing detection was a viable technique that offered a longer range of operation and was the foundation of our visual feedback scheme until it proved to be very prone to errors when even small background objects strayed into view. A final detection technique was implemented, using 940 nm infrared LED beacons mounted on the UAV and a 940 nm bandpass filter mounted on the camera lens to isolate the beacons from other visible spectrum light. This detection scheme provided very reliable UAV position data with few errors, and the IR LED circuit was designed to be powerful enough to drown out stray 940 nm emissions from overhead fluorescent light fixtures.

The implementation of the IR LED circuit and its necessary drivers, however, required placing a greater load on our small-scale UAV, both in terms of weight and battery power consumption. A custom PCB was made to host the IR LED circuit and also provide rigid mounts and connections to two additional and necessary UAV decks - a flight sensor module and an inductive coil wireless charging deck. The combined weight of the custom PCB and supporting decks (47.9 g) exceeded the specified flight payload of the Crazyflie UAV (27.0 g), and we failed to achieve consistent takeoffs until the UAV stock motors were upgraded to higher performance replacements (BETA FPV 7x16mm). Even after demonstrating successful performance with these hardware changes, the additional power consumption demands of the IR LED circuit and the performance motors resulted in a shortening of the maximum flight time that could be provided by the small LiPo batteries compatible with the UAV. This necessitated a modest revision of our engineering requirements related to both UAV flight duration and battery recharge time.

Lastly, the shelter-in-place orders given by state and local authorities in light of the recent coronavirus pandemic prevented us from accessing some key campus resources needed to put finishing touches on the charging platform enclosure. Fortunately, the CAD-modeled mounts designed for our system components were 3D-printed generously by professor Tom Greer at his home workstation and delivered to our team in adherence with widespread social distancing guidelines. Other modifications to the charging platform enclosure, such as a router cut for the wireless charging pad's profile upon the platform enclosure lid, could not be completed.

6. Project Requirements

6.1. Marketing Requirements (MR)

- MR-1.** A complete system will consist of a Crazyflie Quadcopter (UAV) and a charging platform providing for wireless flight control of the UAV without human input.
- MR-2.** The system will be able to land the UAV on a designated point on the charging platform on a UAV low battery signal.
- MR-3.** The charging platform must be able to fully recharge the UAV in a reasonable time frame.
- MR-4.** The charging platform should be able to provide a reasonable amount of recharges for the UAV.
- MR-5.** The UAV should have a reasonable flight time.
- MR-6.** The charging platform will use an upward facing camera to provide necessary feedback for landing the UAV.
- MR-7.** The system must have the ability to operate indoors under normal lighting conditions.
- MR-8.** The system must be portable.
- MR-9.** A personal computer must be able to connect wirelessly to the charging platform to query or reconfigure the control software.
- MR-10.** The UAV must include safety line mounting points.

6.2. Engineering Requirements (ER)

- ER-1.** The UAV will successfully respond to 95% of commands issued remotely by the charging platform at a distance of 3 meters (MR-1).
- ER-2.** UAV will be able to land within 5 cm of target point (MR-2).
- ER-3.** Wireless communication between the charging platform and the UAV will have a latency under 100 ms at 3 meters (MR-2).
- ER-4.** The charging platform will be able to charge the UAV within 1 hour (MR-3).
- ER-5.** The charging platform battery will be able to provide 25 W over 4 hours (MR-4).
- ER-6.** The UAV will be able to fly for at least 3 minutes, with the landing sequence taking no more than 2 minutes (MR-5).
- ER-7.** Charging platform is able to detect an overhead UAV within a height of 2 meters in an indoor environment lit by T8 fluorescent light bulbs (MR-6, MR-7).
- ER-8.** The complete system will fit within a footprint of less than 0.25 m² (MR-8).
- ER-9.** The charging platform control system will support remote connection via SSH (MR-9).
- ER-10.** Anchor point can suspend double the weight of the UAV when attached with 5 lb rated fishing line (MR-10).

7. Implementation

A system will be created that will involve an unmanned aerial vehicle functioning in tandem with a remote charging platform equipped with a centralized control computer, upward-facing camera, and wireless charging pad. The UAV will fly an automated path and alert the charging platform when a battery threshold is crossed. When a low-battery threshold is crossed, a landing sequence will be initiated for the UAV. The landing sequence will consist of aligning the UAV through the use of the charging platform's onboard camera and sending commands for on-the-fly position adjustments through the use of a radio module. The charging platform will allow a remote user to access and receive status updates. The charging platform will be portable, such that it can easily be mounted to an existing platform, indoor structure, or separate vehicle system entirely.

7.1. System Architecture

The system comprises an autonomous UAV and a portable charging platform. Shown in Fig. 2 is a high level block diagram for the entire system. In Fig. 3 the block diagram for the charging platform is shown, and a recent render of the current 3D model for our charging platform is depicted in Fig. 4. In Fig. 5 the software routine for autonomous landing is shown.

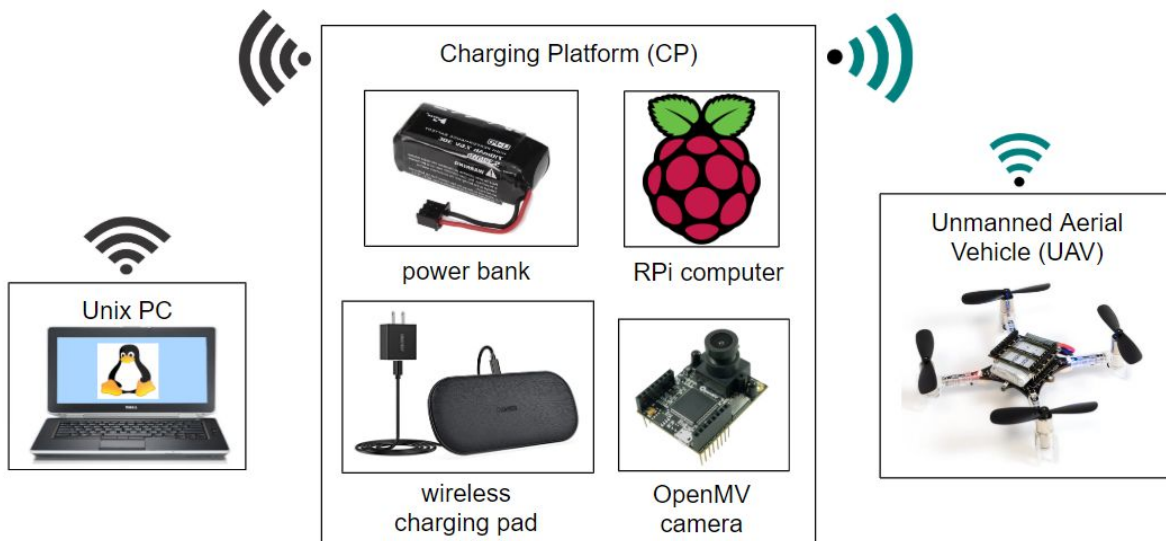

Fig. 2 - High Level Block Diagram

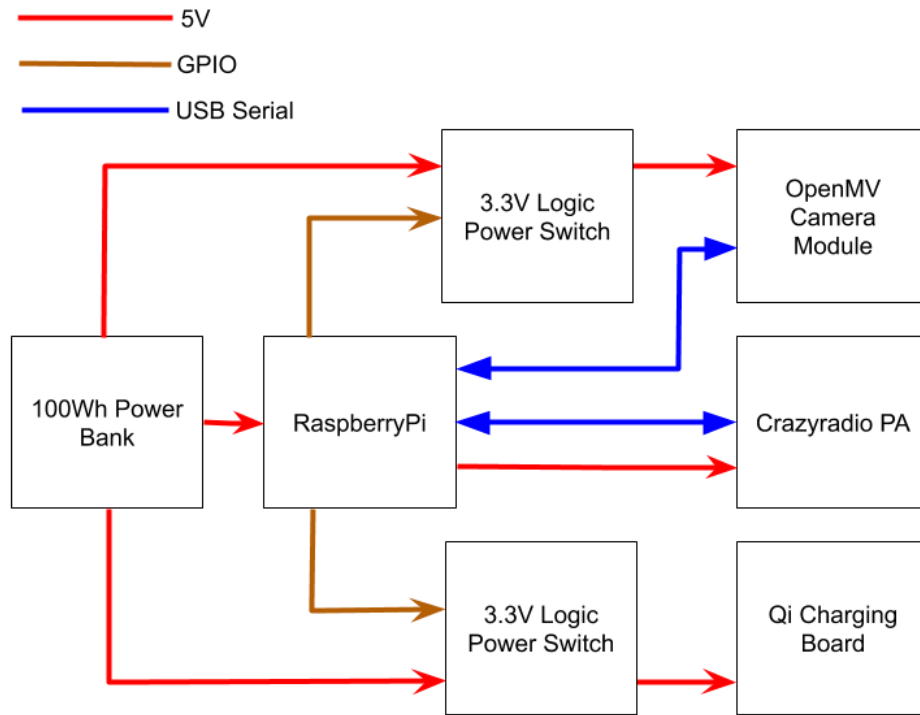

Fig. 3 - Block Diagram of Charging Platform

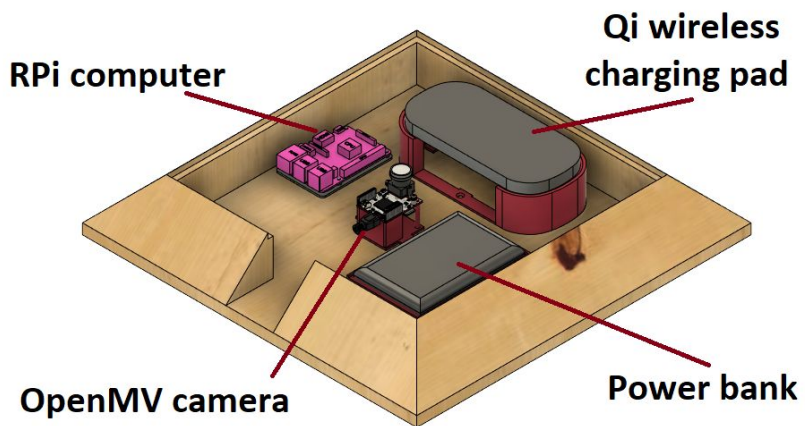

Fig. 4 - CAD Render of Proposed Charging Platform

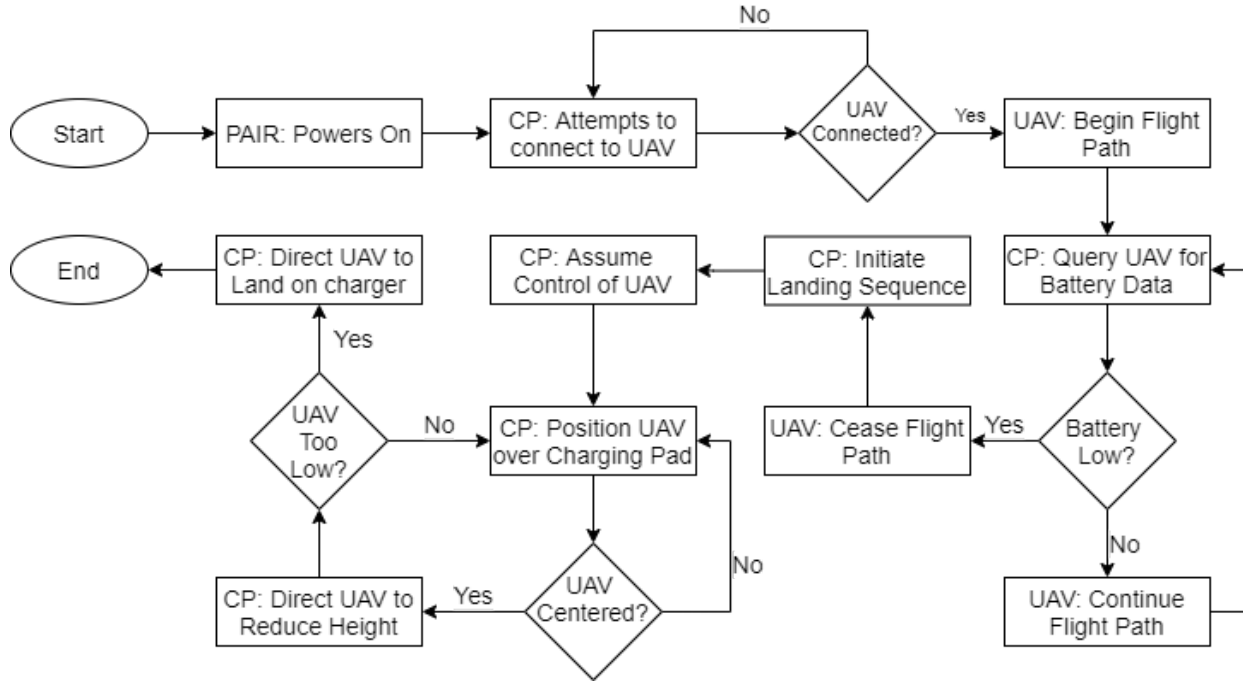

Fig. 5 - Landing Routine Software Flowchart

7.2. Budget/Parts List

Minimizing costs and making efficient use of grant funds is a core consideration of this project. Cost was taken into account at every step of the component selection process. Several premium parts – such as a LattePanda single board computer and higher resolution cameras – were considered, however the low cost solutions shown below were chosen after their capabilities were determined to be sufficient for meeting our Engineering Requirements. A summary of the necessary parts and corresponding project budget is shown in Table 3 below.

There are some additional parts purchased which are not included in the itemized Table 3 below, such as additional Crazyflie 2.1 platforms, an additional Qi charging deck, Flow decks, LED-ring deck, Loco Positioning deck, Z-ranger deck, replacement motors, props, and batteries. These parts are not included in the itemized list below because they are not included in the final product, and were only used for research and development purposes during the project lifecycle.

In Table 1 and Table 2, design matrices are shown for the selection

process of the key system components. The design matrix takes into account several important criteria for the component being selected. The score was based on our evaluations of the product.

Table 1 - Single Board Computer Design Matrix

	Cost	Size	Complexity	Power	Documentation/ Support	
Raspberry Pi 3B+	10	7	8	5	10	40
LattePanda	3	5	5	9	9	31
ASUS Tinker Board S	4	5	2	8	3	22
Raspberry Pi 4	9	5	4	6	5	29

Scoring: 10 is most important /10 is best compared to other options

Description: The 3B+ was chosen because the documentation and support is excellent, as well as the cost. It's performance and ARM limitation should not be a problem for this application. The design matrix is shown above in Table 1.

Conclusion: We plan to use Raspberry Pi 3B+.

Table 2 - Camera Design Matrix

	Cost	Size	Complexity	Power	Documentation/ Support	
OpenMV H7	3	4	10	5	10	32
RasPi Camera	10	7	2	3	3	25
JeVois	3	7	6	7	7	30

Scoring: 10 is most important /10 is best compared to other options

Description: The OpenMV was selected because the documentation and software libraries available were far superior to the openCV and RasPi machine vision libraries. The RasPi camera does not have the same libraries available. The JeVois did not have as much support as desired. The design matrix is shown above in Table 2.

Conclusion: We plan to use the OpenMV H7.

Table 3 - Qi Charger Design Matrix

	Cost	Charging Area	Charging Maximum Distance	Shape	
ZealSound WG-FX6	3	10	4	5	22
CHOETECH T535-S	5	5	5	5	20
Anker A2503	7	2	5	1	15

Scoring: 10 is most important /10 is best compared to other options

Description: Our most important design criteria for the Qi charger was maximizing charging area. The charging speed was not as important in this consideration, as the Qi receiver on the UAV can only supply 2W maximum. For this reason, designs with five coils or greater are most desirable. The ZealSound model was selected initially, however it was discovered that model had unacceptable quality control problems. We selected the CHOETECH model as a replacement, which had comparable charging area, as so far it is serving our purposes quite well.

Conclusion: The CHOETECH 5 coil charging pad will be used.

Table 4 - Summary of parts required and project budget

Part	Description	Number	Price (USD)
Micro UAV platform	Bitcraze Crazyflie 2.1 quadcopter	1	195.00
Wireless charging	Bitcraze Qi 1.2 wireless charging deck	1	30.00

Autonomous Recharging of Unmanned Aerial Vehicle

deck			
Flight sensor deck	Bitcraze Flow Deck v2	1	45.00
Custom UAV deck PCB	Custom PCB for mounting IR beacon, wireless charging deck, and flight sensor deck	1	17.50
UAV performance motors	BETA FPV 7x16mm motors (increased thrust-to-weight ratio from stock motors, 2.6 vs 1.5)	4	27.00
USB power switch PCB	Custom PCB designed to toggle USB power with a 3V3 logic signal	2	30.00
Charging platform materials	Wood, glue, 3D print filament (approximate equivalent materials cost)	n/a	15.00
Wireless charging pad	CHOETECH Dual Fast Wireless Charger	1	27.00
Camera module	OpenMV Cam H7, a small, low power microcontroller board with onboard camera capable of image processing	1	65.00
Infrared filter	Infrared bandpass filter for OpenMV	1	5.00
Wide angle lens	Wide angle lens for OpenMV	1	10.00
5V battery pack	RAVPower 26,800 mAh Power Bank	1	50.00
Single-board computer	Raspberry Pi 3B+	1	40.00
Micro SD card	Micro SD card for single-board computer	1	20.00
Radio module	CrazyRadio PA 2.4 GHz USB radio dongle, compatible with CrazyFlie software	1	30.00
UAV battery	Spare 300 mAh UAV Li-Po batteries (3.7 V)	2	12.00
Misc. supplies & parts	Wire, tools, connectors, electrical tape, etc. (approximate equivalent materials cost)	n/a	50.00
Shipping & Handling	Total shipping for parts used in implementation	n/a	80.00
Total Cost			\$748.50

7.3. Project Schedule

Time in 2019 was spent mostly on planning, research, and proof-of-concept testing. Various hardware options were researched and investigated. High risk challenges were given high priority and completed earlier, such as design and implementation of the landing algorithm, implementing an effective image detection and tracking method, and key viability tests showing that the UAV system and camera were capable of landing with enough accuracy to meet our engineering requirement. Early versions of these milestones were attained on time, and slowly improved as the project went on. A functional prototype of the landing algorithm was ready in December. Further iterations on the landing algorithm continued until accuracy was refined enough to meet the 5 cm accuracy. Similarly, the crude frame difference image detection method was used for January 2020 demos, as it performed quite well under highly controlled settings, with no confounding objects in the frame. This method did not perform well during some demonstrations because the presence of nearby spectators introduced far too many false positives to eliminate. This detection method was later replaced by the much more robust IR detection method in late February, which drastically reduced landing algorithm duration, and eliminated nearly all false positives in our testing environment. The IR method involved an IR LED driver circuit which required a custom PCB to be fitted to the UAV. This PCB also functioned as an expansion frame to secure both the Qi recharging deck and the required flight sensor desk. After many design revisions, the PCB was received in late February. It was discovered that the combined weight of the custom PCB and supporting decks (47.9 g) exceeded the specified flight payload of the Crazyflie UAV (27.0 g), but a solution to this problem was discovered in the middle of March. More powerful motors were fitted to the Crazyflie fuselage, which allowed it to hover and hold its position with the heavier payload, however this greatly decreased flight time, from approximately seven minutes to three minutes. By the time the modified system was retested in March, our access to new hardware and laboratory resources was rapidly becoming impacted by COVID-19, and the decision was made to end the research and development phase of the project, and focus our time on testing and documentation. Furthermore, due to complexity and time constraints, the PCB was not designed to dynamically shut off the high power IR LED beacons, and thus UAV power consumption was increased, both in flight while idling on the ground. As a result, the engineering specifications of this project were rescoped with regard to the system's expected flight time and recharging time.

Table 5 - Gantt chart for project schedule

PROJECT	Autonomous Recharging of Unmanned Aerial Vehicle				
TEAM	Alexander McGinnis, Joseph Haun, Anthony Aboumrad				
DATE	4/18/2020				
DEPARTMENT	Engineering Science, Electrical Engineering				
TASK TITLE	START DATE	END DATE	DATE COMPLETED	Responsible	
Research and Project Planning	Start	End	Completed	Responsible	S E P T O C T V N D E C J A N F E B M A P R
Presentations of Potential Projects	8/26	9/18	9/18	Joe, Alec, Anthony	
Project Title, Abstract, Summary	9/10	9/25	9/25	Anthony	
Project Marketing and Engineering Requirements	9/10	9/25	9/25	Alec	
Advisor Approval Form	9/10	9/25	9/25	Joe	
Order Parts for Testing	9/18	10/9	10/9	Alec	
Block Diagrams	9/18	10/9	10/9	Alec	
Literature Review	10/9	11/6	11/6	Anthony	
Final Project Proposal	10/16	12/4	12/4	Joe, Alec, Anthony	
Design Testing	Start	End	Completed	Responsible	S E P T O C T V N D E C J A N F E B M A P R
Manual Landing of UAV	11/20	12/4	11/23	Alec	
Image Detection Range	11/20	1/18	1/29	Alec	
UAV Command Latency	12/1	12/23	3/10	Joe	
UAV Hover Endurance	12/1	12/23	1/30	Joe	
UAV Mobility Endurance	12/1	12/31	1/30	Joe	
UAV Charge Time	12/11	12/31	1/30	Alec	
System Build	Start	End	Completed	Responsible	S E P T O C T V N D E C J A N F E B M A P R
Project Website	11/20	1/31	12/31	Alec	
Design Charging Platform Structure (3D model)	12/11	1/15	1/14	Anthony	

Autonomous Recharging of Unmanned Aerial Vehicle

Design and fabricate custom PCB boards	12/11	1/22	2/25	Anthony													
Design Algorithm to land UAV	12/11	2/12	1/30	Joe													
Fabricate & Assemble Landing Platform	12/23	2/12	3/9	Anthony													
Implement power switching, sensor module, and interface boards (incl. custom PCBs)	12/23	2/12	3/15	Alec													
Final Project Presentation	1/29	3/4	Incomplete	Joe, Alec, Anthony													
					S	O	N	D	J	F	M	A					
Performance Testing	Start	End	Completed	Responsible	E	P	C	O	E	A	E	A	P				
Network Access Test	11/26	12/4	4/14	Alec	T	T	V	C	N	B	R	R					
UAV Command Reliability	12/18	1/8	1/4	Joe													
Single Board Computer Power Consumption	1/8	2/5	3/1	Alec													
Camera Power Consumption	1/8	2/5	1/10	Alec													
Qi Charger Power Consumption	1/8	2/5	1/30	Alec													
System Battery Life	1/8	2/5	4/17	Anthony													
Software Landing of UAV	1/22	2/29	2/5	Joe													
Landing Routine Duration Test	1/22	2/29	2/28	Joe													
Dimension Measurement	1/29	2/5	2/4	Anthony													
Anchor point weight test	1/29	2/12	2/11	Joe													

8. List of Tests

8.1. Summary of Tests

A variety of Functional Tests (FT) and System Verification Tests (ST) were performed on the UAV-charging platform pair in order to confirm the satisfaction of the project’s Marketing and Engineering Requirements. Below is a summary of the tests conducted, followed by a more detailed description of the test procedures and outcomes.

Table 6 - Summary of tests

Test N u m.	Summary	Mktg. Req #	Eng. Req #	Results	Pass / Fail
FT.1.1.1	UAV Command Responsiveness	MR-1, 2	ER-1, 3	100% response	Pass
FT.2.2.1	Software Landing of UAV	MR-2	ER-2	< 4 cm precision	Pass
FT.2.3.1	UAV Command Latency	MR-2	ER-3	10 ms latency	Pass
FT.3.4.1	UAV Charge Time	MR-3	ER-4	Inconclusive	See Test Description
FT.4.5.1	Camera Power Consumption	MR-4	ER-5	~ 0.8 W	Pass
FT.4.5.2	Qi Charger Power Consumption	MR-4	ER-5	~ 1.8 W	Pass
FT.4.5.3	Single Board Computer Power Consumption	MR-4	ER-5	~ 2-3 W	Pass
ST.4.5.1	System Battery Life	MR-4	ER-5	> 4 h	Pass
FT.5.6.1	UAV Hover Endurance	MR-5	ER-6	~ 3.5 min	See Test Description
FT.5.6.2	UAV Mobility Endurance	MR-5	ER-6	~ 2.3 min	See Test Description
FT.5.6.3	Landing Routine Duration	MR-5	ER-6	~ 40 s	Pass
FT.6.7.1	Image Detection Method Range	MR-6, MR-7	ER-7	~ 3 m	Pass
ST.8.8.1	Dimension Measurement	MR-8	ER-8	40 cm x 40 cm x 7.2 cm	Pass
FT.9.9.1	Network Access Test	MR-9	ER-9	RPi accessible	Pass
ST.10.10.1	Anchor point weight test	MR-10	ER-10	Weight held for 6 hours	Pass

8.2. Description of Tests

FT.1.1.1 - UAV Command Responsiveness: Confirm reliability of wireless communication between charging platform and UAV. (MR-1, ER-1)

- Setup: The UAV established a wireless connection to the charging platform's Single Board Computer (SBC) via CrazyRadio PA module. The SBC ran a Python script that queried the battery voltage on the UAV. The script in question logged the timestamps of both the outgoing query and incoming UAV response. This script was run at increasing distances between the SBC and the UAV.
- Expected Outcome: The UAV will successfully respond to commands sent by the Single Board Computer at least 95% of the time, up to a distance of 3 m.
- Actual Results: At distances ranging from 0 to 3.2 meters, 100% responsiveness was observed for UAV communications (n = 3,767).
- Conclusion: Wireless communication between the charging platform's SBC and the UAV is sufficiently reliable to respond as desired for basic control commands.

FT.2.2.1 - Software Landing of UAV: Perform controlled landings of the aerial vehicle by means of software-automated flight control commands in order to ensure adequate precision of landings upon a target set point. (MR-2, ER-2).

- Setup: The charging platform's SBC was equipped with the Crazyradio PA module and the developed Python script capable of performing autonomous control of the UAV. The SBC was connected to the OpenMV camera module, which ran an image detection method in order to generate the UAV positional information as needed for the SBC to determine flight commands. The UAV was instructed to lift off from a ground location that was approximately 1 m from the OpenMV camera and ascend to a height of 2 m, such that it would enter the vision cone of the camera. The UAV position could then be interpreted from the image detection method, and the SBC attempted to autonomously land the UAV on a target ground point. Both frame differencing and infrared LED beacon image recognition schemes were tested, and all autonomous landings were performed in an indoor environment over a smooth, patterned surface.
- Expected Outcome: Attempts are expected to achieve successful landings to within 5 cm of target, thus demonstrating that software landing can achieve ideal placement upon a wireless charging pad.
- Actual Results: With Frame Differencing, precision of 3.6 ± 0.4 cm (95% C.I., n = 99). With IR LED, precision of 3.4 ± 0.3 cm (95% C.I., n = 125)

- **Conclusion:** Software landings made with machine vision detection methods are well within our target accuracy specifications for both Frame Differencing and IR LED image detection methods.

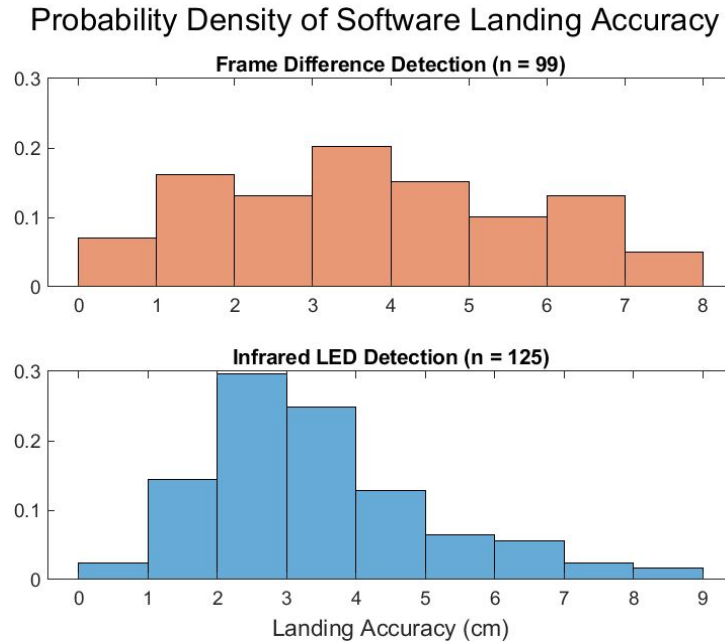

Fig. 6 - Software Landing Accuracy vs. Detection Method

FT.2.3.1 - UAV Command Latency: Determine total command latency from the issuance of a single query command by the Single Board Computer (SBC) to a corresponding response by the UAV control board. (MR-2, ER-3).

- **Setup:** The UAV established a wireless connection to the charging platform's Single Board Computer (SBC) via CrazyRadio PA module. The SBC ran a Python script that queried the battery voltage on the UAV. The script in question logged the timestamps of both the outgoing query and incoming UAV response. This script was run at increasing distances between the SBC and the UAV.
- **Expected Outcome:** The latency between the battery voltage query and the UAV response will be less than 100 ms for adequate control timing. [9]
- **Actual Results:** Latency was approximately 10 ms at each distance ($n \geq 450$ for all), with an average of 9.99 ± 0.36 ms at 3.2 meters ($n = 467$).
- **Conclusion:** Wireless communication between the charging platform's SBC and the UAV is rapid enough to respond as desired for basic control commands.

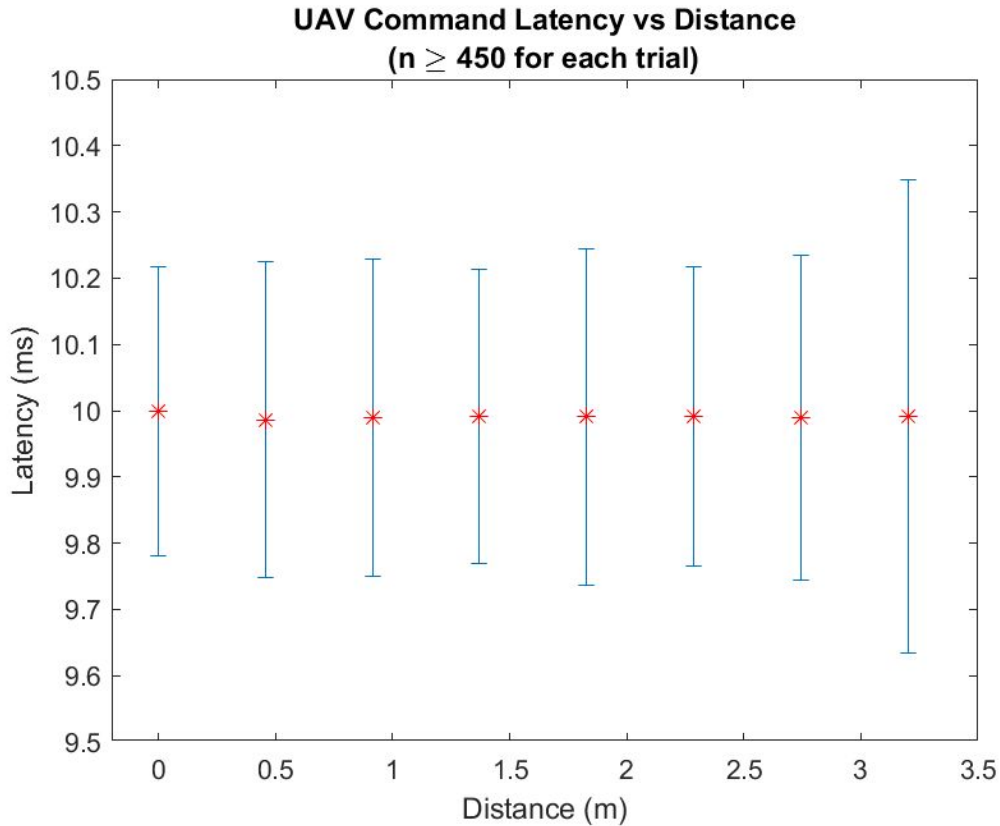

Fig. 7 - UAV Command Latency vs. Distance

FT.3.4.1 - UAV Charge Time: Determine the total time required to charge the UAV battery using the Qi wireless charging pad. (MR-3, ER-4).

- **Setup:** A series of tests were planned to perform timed trials of UAV wireless recharging for both of the available LiPo battery configurations (250 mAh and 380 mAh). The UAV would perform flight operations until its battery was depleted to the point of being unable to maintain flight. The UAV would then be recharged until it reported a full battery status to the charging platform's SBC. As of April, undetermined hardware failures have prevented the completion of these trials. Repeated attempts to charge the UAV both wirelessly via Qi charging pad and directly via USB power supply have yielded either zero retained charge or electrolyte decomposition (as exhibited by LiPo battery swelling). Prior to our decision to refrain from further recharge attempts until access to spare batteries and/or alternative Qi charging pad options were available, two test results were documented - one completed recharge with the 250 mAh UAV battery via Qi wireless charging pad (albeit prior to the custom PCB implementation), and one complete recharge with the 250 mAh battery via direct USB-connected power supply (and including the custom PCB).

Autonomous Recharging of Unmanned Aerial Vehicle

- Expected Outcome: The UAV battery will be fully charged within 1 hour.
- Actual Results: An initial wireless recharging trial with the 250 mAh battery but without the custom PCB was completed in 75 minutes. A direct USB recharge of the UAV with the 250 mAh battery and custom PCB took 2 hours and 17 minutes. All other trial attempts resulted in battery failure.

Conclusion: Neither of the recorded trials is a direct analog to the final system implementation, and iterative testing could not be completed at this time without severe risk of losing functionality of our remaining LiPo batteries. Due to recent shelter-in-place orders which preclude access to electrical laboratory equipment, further troubleshooting of hardware failures could not be adequately performed at team members' residential work spaces. As we are not able to diagnose and resolve the UAV recharging problems at this time, we must defer the determination of the specified UAV wireless recharge time to future works.

FT.4.5.1 - Camera Power Consumption: Test the power consumed by the camera when our chosen image detection method is running. (MR-4, ER-5)

- Setup: The camera module ran a specific image detection method. The power consumption over a 25 minute period was determined via USB power monitor. The test was performed once while a detectable object was the frame and once without any detectable object in frame.
- Expected Outcome: The Camera module will consume no more than 5 W, regardless of whether or not a detectable object is in frame.
- Actual Results: The mean power consumption for the camera was 734 ± 5 mW (95% C.I., $n = 1,617$) during idle state, and 776 ± 0.3 mW (95% C.I., $n = 1,874$) during active detection.
- Conclusion: The camera module meets the specified power requirements.

FT.4.5.2 - Qi Charger Power Consumption: Test power consumption of Qi charger while actively recharging UAV battery. (MR-4, ER-5)

- Setup: A USB power consumption monitor was placed inline with the transmitting Qi charger while the operating UAV battery (OEM 250 mAh LiPo) was charging. The power consumption measurements, sampled every second, were averaged over the recorded test period.
- Expected Outcome: Qi charger should consume no more than 10 W.
- Actual Results: Average power draw of 1.823 W over a 75 minute charging period.
- Conclusion: The Qi charger meets the specified power requirements.

FT.4.5.3 - Single Board Computer Power Consumption: Test power consumption of single board computer in charging platform. (MR-4, ER-5)

- **Setup:** A USB power consumption monitor was placed inline with the single board computer (SBC) and a suitable power supply. The SBC was allowed to idle for 25 minutes while idle-state power consumption measurements were taken. The SBC power consumption was then measured while running a fourth-thread stress test program which utilized > 75% CPU capacity for 25 minutes. For both test iterations, the power consumption measurements, sampled every second, were averaged over the recorded test period.
- **Expected Outcome:** Single board computer will consume no more than 15 W during either test iteration.
- **Actual Results:** The mean power consumption for the SBC was 2.197 ± 0.005 W (95% C.I., n = 1,459) during idle state, and 2.843 ± 0.004 W (95% C.I., n = 1,721) during stress test.
- **Conclusion:** The single board computer meets the specified power requirements.

ST.4.5.1 - System Battery Life: Confirm that the charging platform's battery supports system operation at 25 W over the specified time period of 4 hours. (MR-4, ER-5)

- **Setup:** An initial test was planned which involved powering all charging platform components at maximum usage by the fully-charged 5 V battery pack, as specified by the system design. The system's total operation time until failure of at least one component would be measured. However, due to considerations for our project budget, should the \$50 battery pack become damaged during a stress test, we deemed that reliance on manufacturer specifications for both energy storage and current limits to be reasonably accurate.
- **Expected Outcome:** The combined power consumption of all core subsystem components shall not exceed 25 W and the battery pack shall be capable of providing at least this amount and maintain operation for at least 4 hours. (See Functional Tests 4.5.1 through 4.5.3 above for rough breakdown of component power limits). The expected endurance of the system will be projected from these manufacturer specifications.
- **Actual Results:** The component power consumption tests described above suggested a maximum total system power requirement of approximately 5.442 W, which was far less than our early, rough estimates. The 5V battery pack selected for the charging platform (RAVPower 26,800 mAh Power Bank) is specified by its manufacturer to provide a maximum of 27.5 W. At 5V, the 26,800 mAh capacity of the battery pack yields 134 Watt-hours, which would offer 4.87 hours of operation at its maximum power, 27.5 W. At the system power requirements as tested (5.442 W), our charging platform may be expected to operate at maximum capacity for 24.6 hours. This estimate does not take into

account any potential power savings from configuring the SBC software to turn off the OpenMV camera and/or Qi charging pad when not in use, which would be possible with the custom power switching PCBs designed as potential accessories to our charging platform. Nonetheless, our projected (and to-date, unverified) system power specifications are roughly 5.5 W operating power, up to 24 hours of continuous operation on the selected 5V battery pack.

- Conclusion: The 5V battery pack provided more than our expected needs and far more than the actual power requirements of the subsystem. A verification of any projected specifications has not been performed at this time, but the system can be reasonably expected to operate for at least 4 hours, and likely 2 or 3 times this duration.

FT.5.6.1 - UAV Hover Endurance: Determine the total amount of time the UAV is able to hover for the two available battery capacities (250 mAh and 380 mAh). (MR-5, ER-6)

- Setup: Begin timing UAV once it lifts off and commences a software-defined hover routine at a fixed height from the ground. Continue timing until the UAV is unable to maintain the hover height.
- Expected Outcome: UAV hovers for at least 5 minutes with each battery.
- Actual Results: Initially, the stock Crazyflie UAV was able to hover for 6 minutes with a 250 mAh battery and 8 minutes with a 380 mAh battery. On subsequent re-test with the additional hardware payload (custom PCB and performance motors), the UAV was able to hover for 3.52 minutes on average with the 250 mAh battery.
- Conclusion: Initial tests of the Crazyflie 2.1 hardware met expectations, however later tests did not, due to late-stage hardware changes. As a result of the additional weight and power consumption from the performance motors and IR LED circuit, the UAV flight time was reduced by over one half as a result of these changes. To meet our previously-stated goals, the additional hardware would need to be removed. As this is not possible without compromising the key functionalities of our system, our flight duration specification will have to be adjusted to reflect the current implementation.

FT.5.6.2 - UAV Mobility Endurance: Determine the total amount of time the UAV is able to fly a given autonomous flight pattern. This pattern could either be in the horizontal or vertical planes. (MR-5, ER-6)

- Setup: Two autonomous flight routines will be performed by a UAV equipped with a fully-charged onboard battery. The first routine will be a horizontal figure-eight pattern and the second will be a vertical figure-eight pattern. The UAV will be timed from initial take-off until flight failure due to inadequate battery power. The tests were performed with 250 mAh batteries.

Autonomous Recharging of Unmanned Aerial Vehicle

- Expected Outcome: UAV will be able to maintain either autonomous flight routine for at least five minutes.
- Actual Results: Initially, the stock Crazyflie UAV was able to perform the autonomous flight maneuver for 6 minutes with a 250 mAh battery and 7 minutes with a 380 mAh battery. On subsequent re-test with the additional hardware payload (custom PCB and performance motors), the UAV was able to perform the maneuver 2.33 minutes on average with the 250 mAh battery.
- Conclusion: Initial tests of the Crazyflie 2.1 hardware met expectations, however later tests did not, due to late-stage hardware changes. As a result of the additional weight and power consumption from the performance motors and IR LED circuit, the UAV flight time was reduced by over one half as a result of these changes. To meet our previously-stated goals, the additional hardware would need to be removed. As this is not possible without compromising the key functionalities of our system, our flight duration specification will have to be adjusted to reflect the current implementation.

FT.5.6.3 - Landing Routine Duration: Determine the total amount of time required to autonomously land the UAV. (MR-5, ER-6)

- Setup: An in-flight UAV was positioned at the edge of the charging platform's detectable range, at a height of 2.3 m and approximately 0.76 meters from the camera as projected onto the landing space. The UAV angle was known for the entire duration. The completion of the autonomous landing sequence was timed in software, and only successful landings were considered to be valid data points.
- Expected Outcome: The time trials should indicate that successful landings can be made within two minutes for all specified image detection schemes.
- Actual Results: Use of the Frame Differencing image detection method resulted in an autonomous landing sequence completion time of 156.411 ± 7.422 seconds (95% C.I., $n = 49$). Use of the IR LED detection method resulted in an autonomous landing sequence completion time of 39.567 ± 0.445 seconds (95% C.I., $n = 125$)
- Conclusion: The autonomous landing program was successful in completing landings of a UAV in its field of view within our target timeframe, and the IR LED image detection method was far more capable at quickly providing accurate UAV positioning information to the SBC when compared to Frame Differencing.

Landing Sequence Duration of Two Image Detection Methods

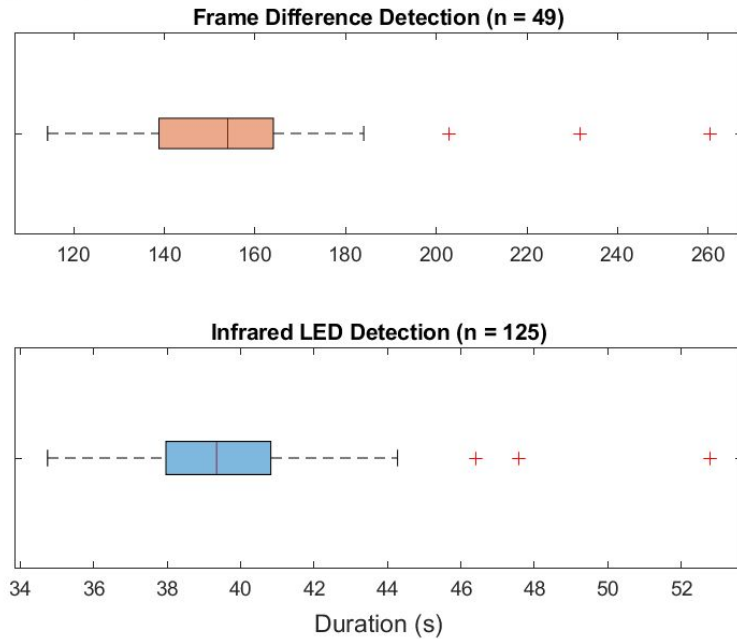

Fig. 8 - Landing Sequence Duration vs. Detection Method

FT.6.7.1 - Image Detection Method Range: Determine the range of reliable UAV detection by various image detection methods. (MR-6, MR-7, ER-7)

- **Setup:** The camera module was configured for a desired image-recognition mode. The UAV was manually brought into frame and raised to various height intervals to determine the limits of reliably detecting the UAV with a given image detection method (RGB detection, April Tag, Frame Difference, and IR LED detection). This range determination was made for each of the various image-recognition modes by monitoring real-time detection success over a serial interface.
- **Expected Outcome:** The camera module should consistently detect the UAV up to 2 meters in an indoor environment lit by T8 fluorescent light bulbs.
- **Actual Results:** The camera module reliably detected the UAV up to 2.79 m, 1.52 m, 1.83 m, and 3.08 m for the RGB, April Tag, Frame Difference, and IR LED detection methods, respectively. The Frame Difference detection method was observed to be very sensitive to errors from background disturbances in frame, such as human passersby or a shimmer of reflected light.
- **Conclusion:** IR LED beacons provided the most reliable detection within our test parameters, and faster frame rate than RGB detection. It was the most ideal choice for the scope of our system, and exceeded our target detection range specification of 2 meters.

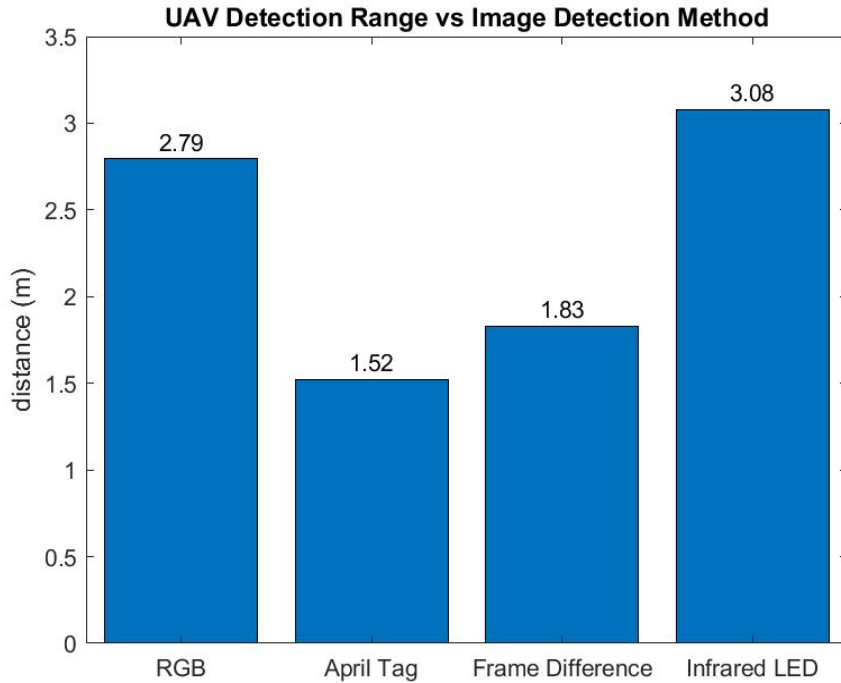

Fig. 9 - Detection Range vs. Method

ST.8.8.1 - Dimension Measurement: Confirm that the complete system is constrained to a size which supports portability. (MR-8, ER-8)

- Setup: The charging platform's physical dimensions will be measured with a ruler and its footprint will be determined.
- Expected Outcome: As modeled and as assembled, the charging platform will have a footprint under 0.25 m².
- Actual Results: Charging platform enclosure was measured to have dimensions of 40 cm x 40 cm x 7.2 cm, resulting in a footprint of 0.16 m².
- Conclusion: The charging platform meets its modeled specifications for a portable size.

FT.9.9.1 - Network Access Test: Confirm that charging platform's single board computer can be accessed via SSH (MR-9, ER-9)

- Setup: 100 SSH connections were made and the resulting connection success pass/fail variable was recorded to a log file.
- Expected Outcome: The single board computer should be able to make a successful connection 95% of the time.
- Actual Results: 100/100 SSH attempts connected to the remote shell successfully
- Conclusion: Network access reliability is more than adequate for our system.

FT.10.10.1 - Anchor Point Weight Test: Confirm that the UAV anchor points will support twice the weight of the UAV on an anchor line. (MR-10, ER-10)

- Setup: A 5 lb fishing line will be affixed to the UAV anchor point, with its loose end secured to a weight equivalent to twice the weight of the UAV. The UAV will be securely mounted to a fixed structure while the anchor point's durability is tested with the freely-hanging weight.
- Expected Outcome: The anchor point will not fail, and support the specified weight without compromising its structural integrity.
- Actual Results: The anchor point was able to hold the UAV along with an added NEMA 17 stepper motor for over six hours.
- Conclusion: The anchor point exceeds weight specifications and will operate as expected.

8.3. Preliminary Results

Within the scope of this proposed charging platform system, we have demonstrated the achievement of the crucial functionalities required for addressing the problem stated at the outset. Namely, the limited accessibility of autonomous UAV landing and recharging systems to small-scale UAV developers.

A primary functional challenge of our project was the development of a sufficiently-accurate autonomous software landing routine for a small-scale UAV, as made possible by a combination of image detection by the OpenMV camera and the generation of autonomous flight controls issued by the SBC. As such, our key metrics of success considered the accuracy and precision of both of these functions. For image recognition, we initially implemented a combination of frame difference detection and edge detection methods, which accurately tracked the UAV without the need for any identifying markers. The downsides of this technique was that small perturbations in the background resulted in high frequency noise that contributed to inaccuracy in determination of the UAV blob centroid. This compromised the maximum distance for which camera was able to detect the UAV, shown in Figure 9. An improvement of the error rate was attempted by making use of an April Tag detection script which accurately and rapidly tracked the location of a bottom-mounted April Tag on the UAV. The drawback of this technique was that the camera frame required digital cropping, due to the limited RAM of the OpenMV camera. This greatly decreased the camera's vision cone. An RGB detection method was also tested, which demonstrated acceptable performance when the UAV was close to the camera, but the large amount of RGB pixel information caused other limitations to this technique, such as reduced frame rates. The current and most reliably-accurate detection option tested for our system implementation involved the use of two 940 nm IR LED beacons

mounted to the underside of our UAV by means of the custom PCB. After installing a 940 nm band-pass optical filter on the OpenMV camera, the target IR beacons were readily distinguishable from virtually every other object in the vision cone.

When used to determine the position of the UAV in the world frame, this infrared LED detection method enabled our landing routine software to issue flight commands that resulted in close-proximity landings upon a wireless charging pad. For a UAV of known bearing at the edge of the camera's vision cone, these landings can be completed in approximately 40 seconds and are accurate to within 4 cm of the specified target point. All networking and communication capabilities of the charging platform have been shown to be highly reliable, and multiple mechanical considerations have been made to meet customer requirements as well. (e.g. dimensions ensuring portability and the durability of a UAV anchor for secure mounting to a safety line). The charging platform consumes approximately 5.442 W of power, and can be expected to operate upwards of 20 hours (and potentially 24) with the selected battery pack, which far exceeds our initial specifications for the onboard power system.

Our implemented system met virtually every engineering requirement established in our original proposal. Minor revisions were made to the tentative specifications of the current expected UAV flight duration and wireless recharging time, as the accomplishment of our more ambitious expectations would entail a more in-depth redesign of the custom PCB (including its IR LED driver circuit) and/or wireless charging components that would be most appropriately pursued as a future work. The UAV, as currently mounted with the custom PCB, can be expected to maintain flight for 2 to 3 minutes on a fully-charged 250 mAh battery, but these specifications remain tentative until a future endeavor is able to provide a more efficient implementation of necessary UAV hardware. The wireless recharging capabilities of the charging platform are currently inconclusive, but continued trials involving alternatives to the selected Qi inductive coil charging components may be pursued in a future work.

Wherever possible, we designed the system with open-source principles and component affordability in mind. This was intended to make our system accessible and adaptable for other small-scale UAV developers. We hope that the results of this project enable future iterations to expand these developments into more sophisticated autonomous UAV recharging systems. These outcomes could involve either larger, more capable drones that can carry meaningful payloads, or simply better tools for researchers interested in focusing their design efforts on other aspects of UAV autonomy. The Bitcraze Crazyflie user base contains a thriving open-source community, and using this UAV model for our implementation means that there may be numerous outside developers who are interested in further iterations of this design.

9. Customer Survey

In order to evaluate customer attitudes, expectations, and need for the product, several interviews were conducted with individuals interested in the system. To begin the customer survey process, preliminary questions were determined to engage the customer and begin an open dialogue where they might share their experience. By asking open ended questions, the potential customers are encouraged to disclose insights which might answer questions our team might never have thought of. Some examples of questions that were asked during the interview were

- What are you or your organization going to use this system for?
- Under what conditions do you want this system to be capable of operating in?
- What performance do you expect out of this system?

Some more specific questions were asked as well

- How long should the landing routine take?
- How much of the battery should the landing routine take?
- What safety precautions should be in place?
- What failure rate should this system have?
- What flight-time should the UAV have?

Two potential customers were interviewed. This first is a postgraduate student, specializing in robotics, who is researching and teaching at the University of Southern California in Los Angeles. The second is a mechanical engineer that is currently working at Lawrence-Berkeley National Laboratories.

For the specific questions asked in the interviews, the customers did not always have specific answers. The common themes between the two customers were given the most weight for consideration, which included that the landing should be highly reliable and require little human intervention, and that the landing should consume a small amount of battery power, as the drones will already be low on power. It is important to note that several desires expressed by the customers were deemed to be too ambitious for the first step, and left to future work outside of the scope of this senior design project. The marketing requirements listed above represent an aggregate of the desires expressed by the potential customers interviewed.

10. Regulation Compliance of Our Project

In the Safety and Health Information Bulletin Preventing Fire and/or Explosion Injury from Small and Wearable Lithium Battery Powered Devices (SHIB 06-20-2019) from the Occupational Safety and Health Administration (OSHA) several guidelines for how to safely handle lithium batteries are enumerated. These guidelines include proper prevention procedures and employee training procedures. The bulletin states that employees should be trained on how to properly identify defective, damaged, or otherwise failing lithium powered devices and batteries. Additionally, employees should be trained to immediately remove defective devices and batteries from the workplace. Employees should also be trained to quickly remove lithium devices which are worn on the body, if the device feels hot or is leaking, releasing gas, hissing, bulging, cracking, or on fire [12]. When lithium batteries become damaged, they present a fire and explosion hazard. They can be damaged by improper charging, short-circuit, or physical damage. For this reason, lithium battery users must be vigilant to avoid hazards related to these devices. These hazards include physical impacts which damage lithium batteries through crushing, dropping or puncturing and charging the devices with unsuitable chargers [12].

As the system will be designed for indoor use, many of the Federal Aviation Administration's (FAA) guidelines do not apply to the system being created. So long as it is flown indoors, which is not FAA controlled airspace, the operators of the system will not be required to receive any certification through the FAA [13]. However, if the system were to be taken outdoors, any operator of the system would be required to qualify for an Airman Certification through the FAA that will legally allow the operation of the UAV within controlled airspace under Part 107 of the FAA regulations [13]. If the UAV were to be substituted for another the operator making the substitution will be required to review FAA Part 107 to determine if their UAV requires registration prior to flight outdoors [13]. As this system contains a UAV that is lighter than 0.55 lb, it does not require registration with the FAA. If this system were to be taken overseas, the operator of the system would be required to comply with their current location's equivalent to the FAA as well as receiving any specific certification required by the local FAA equivalent [13].

Given the safety and regulatory considerations described above, we must also be prepared to provide sufficient guidance to our intended customer as to the employer training requirements covered by the OSHA Training Standards Policy Statement (Memorandum 04-28-2019). [14] Per OSHA training standards, these guidelines listed must be provided in a clear, readable manner to the intended operator. To this effect, both written and verbal training will be prepared so that any operator of the system may be instructed by designers as well as reference a comprehensive document that details the safe operation and safe operating environments of the system per given regulations. If the system is to be operated outside these

specified environments, the operator will be instructed to review and consult with relevant authorities to ensure that they are operating the system in a safe and legal manner for their desired environment. The instructions must also provide the safety regulations detailing the proper handling of all components of the system including the lithium polymer batteries in the charging platform, lithium polymer batteries in the UAV, and any other electronics present within the system in both operation and disposal.

11. Ethics of the Engineering Profession and Our Project

The IEEE code of ethics is what we, as aspiring electrical engineers, will use to determine our behavior and choices throughout this project. The first point of this code is that we will “hold paramount the safety, health, and welfare, to the public” [10] as we are detailing a system that potentially would injure someone in the case of malfunction we will ensure that all pieces of the system are fully tested and will operate within specification and intent. We will “strive to comply with ethical design and sustainable development practices” [10] by providing reputable sources for all components used within this product as well as sources for any idea that was used to help create this system that is not within our control. As a large part of this design process we will “seek, accept, and offer honest criticism of technical work” [10] from both our mentors as well as our peers. We will do this by scheduling appointments and engaging in frank discussions about the progress we are making and steps that need to be taken to create the best product available while still following our own ethical guidelines as well as that of the university. As a product that will be available for the public, we will avoid “pandering to lurid curiosity” [11] and “undertake technological tasks for others only if qualified by training or experience” [10] and if necessary we will “maintain and improve our technical competence” [10] through research and consultations with more experienced members of our chosen profession. We will also “assist colleagues and co-workers in their professional development” [10] by helping to create an environment that is welcoming of criticism and allows for open dialogue regardless of relative situations.

References

- [1] - M. LaFay, “Popular Uses for Drones,” *dummies*. [Online]. Available: <https://www.dummies.com/consumer-electronics/drones/popular-uses-for-drones/>. [Accessed: 07-Nov-2019].
- [2] - L. Brown, “Top 10 Drones with Longest Flight Time for 2019,” *[OFFICIAL] Wondershare Filmora - Easy, Trendy and Quality Video Editor*, 06-Aug-2019. [Online]. Available: <https://filmora.wondershare.com/drones/drones-with-longest-flight-time.html>. [Accessed: 23-Oct-2019].
- [3] - S. Burns, “Drone meets delivery truck,” *UPS*, 22-Feb-2017. [Online]. Available: <https://www.ups.com/us/es/services/knowledge-center/article.page?kid=cd18bdc2>. [Accessed: 23-Oct-2019].
- [4] - M. Wilson, “How to Keep Up with Rising Consumer Shipping Expectations,” *afflink*, 04-Sep-2019. [Online]. Available: <https://www.afflink.com/blog/how-to-keep-up-with-rising-consumer-shipping-expectations>. [Accessed: 07-Nov-2019].
- [5] - K. E. Wenzel, A. Masselli, and A. Zell, “Automatic Take Off, Tracking and Landing of a Miniature UAV on a Moving Carrier Vehicle,” *Journal of Intelligent & Robotic Systems*, vol. 61, no. 1-4, pp. 221–238, Jan. 2011.
- [6] - J-K. Lee, H. Jung, H. Hu, and D. H. Kim, “Collaborative control of UAV/UGV,” *2014 11th International Conference on Ubiquitous Robots and Ambient Intelligence (URAI)*, pp. 641–645, Nov. 2014.
- [7] - Y. Wei, H. Qiu, Y. Liu, J. Du, and M.-O. Pun, “Unmanned aerial vehicle (UAV)-assisted unmanned ground vehicle (UGV) systems design, implementation and optimization,” *2017 3rd IEEE International Conference on Computer and Communications (ICCC)*, Dec. 2017.
- [8] - N.Wu, C. Chacon, Z. Hakl, K. Petty, and D. Smith, “Design and Implementation of an Unmanned Aerial and Ground Vehicle Recharging System,” *NAECON - IEEE National Aerospace and Electronics Conference, Dayton, OH, 2019*.
- [9] - Bitcraze AB, “The Crazyflie Python API,” *Bitcraze*. [Online]. Available: https://www.bitcraze.io/docs/crazyflie-lib-python/master/python_api/. [Accessed: 25-Nov-2019].
- [10] - “IEEE Code of Ethics,” *IEEE*. [Online]. Available: <https://www.ieee.org/about/corporate/governance/p7-8.html>. [Accessed: 27-Nov-2019].

Autonomous Recharging of Unmanned Aerial Vehicle

- [11] - “SPJ Code of Ethics - Society of Professional Journalists,” *Society of Professional Journalists - Improving and protecting journalism since 1909*. [Online]. Available: <https://www.spj.org/ethicscode.asp>. [Accessed: 27-Nov-2019].
- [12] - Occupational Safety and Health Administration, “Preventing Fire and/or Explosion Injury from Small and Wearable Lithium Battery Powered Devices,” *Safety and Health Information Bulletins*. [Online]. Available: <https://www.osha.gov/dts/shib/shib011819.html>. [Accessed: 11-Dec-2019].
- [13] - Federal Aviation Administration, “Commercial Operations Branch | Part 107 UAS Operations,” *FAA | Flight Standards Service*, 27-Sep-2018. [Online]. Available: https://www.faa.gov/about/office_org/headquarters_offices/avs/offices/afx/afs/afs800/afs820/part107_oper/. [Accessed: 11-Dec-2019].
- [14] - D. Michaels, “OSHA Training Standards Policy Statements,” *Occupational Safety and Health Administration*, 28-Apr-2019. [Online]. Available: <https://www.osha.gov/laws-regs/standardinterpretations/2010-04-28>. [Accessed: 11-Dec-2019].